



# Planetary Mixers Planetary Mixer, 30 lt - with Hub

ITEM # \_\_\_\_\_

MODEL # \_\_\_\_\_

NAME # \_\_\_\_\_

SIS # \_\_\_\_\_

AIA # \_\_\_\_\_



**600164 (DXBM30AB3)**

30 lt planetary mixer, bowl detection device and solid bowl guard, with mechanical speed variation. Equipped with spiral hook, paddle, whisk and H type accessory hub

## Short Form Specification

Item No. \_\_\_\_\_

Floor model, suitable for all kneading, blending and whipping operations. Body in non-corrosive material with 18/8 (AISI 302) 30 litre capacity stainless steel bowl. Powerful asynchronous motor (750 W) with mechanical speed variator (8 speed levels from 35 to 180 rpm). Water protected planetary system. Removable/transparent solid safety screen - made of a bisphenol-A free (BPA) copolyester. Removable and dismantled solid safety screen and stainless steel wire structure. Water proof (IP55) and flat touch button control panel with 60 min. timer. Bowl detection device allows the mixer to switch on only when the bowl and the safety screen are properly installed and positioned together. Adjustable feet for stability. Equipped with accessory drive hub type H (accessories are not included). Supplied with 3 tools: spiral hook, paddle and whisk.

## Main Features

- Professional beater mixer that provides all the basic mixer functions: kneading of all sort of pastes, mixing of semi-liquid products, emulsions and various sauces.
- Delivered with:
  - Spiral Hook, Paddle, Wire Whisk and Mixing Bowl for 30 lt
  - Accessory drive hub (accessories are not included)
- Waterproof touch button control panel with timer setting and display.
- Mechanical speed variator.
- Maximum capacity (flour, with 60% of hydration) 7 kg, suitable for 100-300 meals per service.
- Raising and lowering of the bowl controlled by lever with an automatic locking of the bowl when in the raised position.
- Solid BPA-free safety screen, covering the stainless steel wire one, limits the flour and unsafe dust particles when used in bakery and pastry preparation.
- Removable chute to add ingredients while working included as standard.
- Bowl detection device allows the mixer to switch on only when the bowl and the solid safety screen are properly installed and positioned together.

## Construction

- Body in non-corrosive material.
- Sturdy construction with mechanically welded strong metal frame.
- 302 AISI Stainless steel bowl - 30 lt. capacity.
- Asynchronous motor with high start-up torque.
- 8 speeds, from 35 to 180 prm, to be lever operated while the machine is working, according to the tool and the mixture hardness.
- Water protected planetary system (IP55 electrical controls, IP23 overall machine).
- Power: 750 watts.
- Planetary movement based on self lubricating gears, eliminating any risk of leaks.
- The solid safety screen and the stainless steel wire structure are both removable and dismantled for cleaning and are dishwasher safe.
- Adjustable feet for perfect stability.

## Included Accessories

- 1 of BOWL FOR 30LT MIXER PNC 650123
- 1 of DOUGH HOOK FOR 30LT MIXER PNC 653161
- 1 of PADDLE FOR 30LT MIXER PNC 653165
- 1 of WHISK FOR 30LT MIXER PNC 653166

## Optional Accessories

- BOWL FOR 30LT MIXER PNC 650123 □

APPROVAL: \_\_\_\_\_



## Planetary Mixers Planetary Mixer, 30 lt - with Hub

- 10L BOWL,HOOK,PAD, WHISK+ SPOUT-30L MIXER PNC 650124
- 20L BOWL,HOOK,PADDLE,WHISK FOR 30L MIXER PNC 650125
- DOUGH HOOK FOR 30LT MIXER PNC 653161
- PADDLE FOR 30LT MIXER PNC 653165
- WHISK FOR 30LT MIXER PNC 653166
- PUREE STRAINER FOR H HUB WITH 3 GRIDS PNC 653187
- VEGETAB.CUTTER H HUB+ EJECTOR-DISCONNECT. PNC 653225
- REINFORCED WHISK FOR 30LT MIXER PNC 653253
- KIT WHEELS FOR (XB)20/30/40L PLAN.MIXERS PNC 653552
- Bowl trolley for 30 lt planetary mixers (cannot be used with wheel kit 653552) PNC 653562
- EXT.SUPPORT(ALUM)-MEAT MINCER 70MM-H HUB PNC 653720
- ALUM.MEATMINCER KIT 70MM-H HUB-ENTERPRIS PNC 653721
- S/S MEATMINCER KIT 70MM-H HUB-ENTERPRISE PNC 653722
- S/S MEATMINCER KIT 70MM-H HUB-½ UNGER PNC 653723



Planetary Mixers  
Planetary Mixer, 30 lt - with Hub  
The company reserves the right to make modifications to the products without prior notice. All information correct at time of printing.

2026.04.21

Front

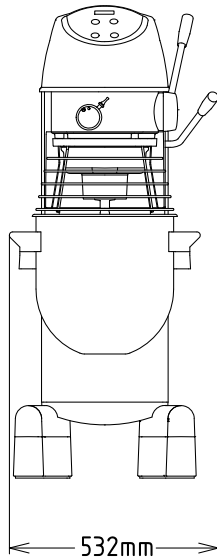

Electric

**Supply voltage:** 200-240/380-415 V/3 ph/50 Hz  
**Electrical power max.:** 0.75 kW  
**Total Watts:** 0.75 kW

**Capacity:**

**Performance (up to):** 7 kg/Cycle  
**Capacity:** 30 litres

**Key Information:**

**External dimensions, Width:** 532 mm

**External dimensions, Depth:** 685 mm

**External dimensions, Height:** 1230 mm

**Shipping weight:** 116 kg  
**Cold water paste:** 7 kg with Spiral hook  
**Egg whites:** 50 with Whisk

Side

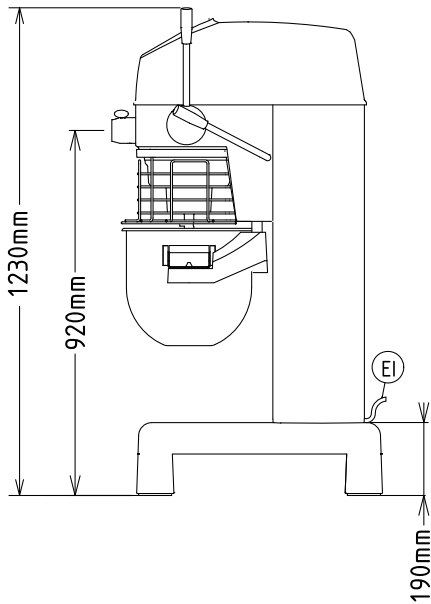

**EI** = Electrical inlet (power)

Top

